

TUFFY | PowerLoad

Zero Emission—Battery-Powered Pressure Washer—Quiet Operation

With “Optional” High Efficiency Heater

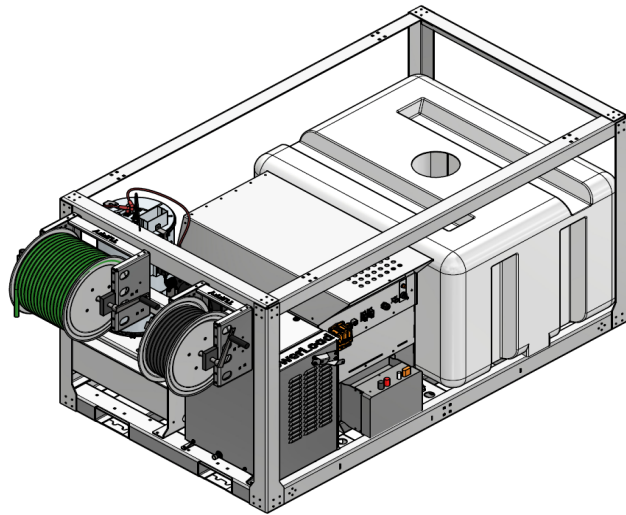

4 GPM
4000 PSI

NO MORE
GASOLINE

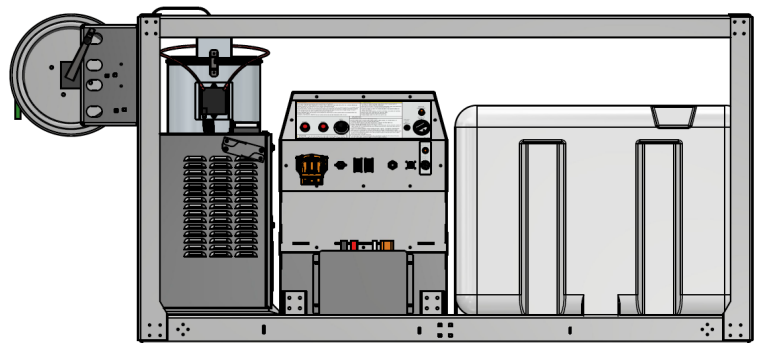

With lower operating costs, the TUFFY PowerLoad will save on average \$5.00/hour

Full Day of Work on a Single Charge



100% Battery-Powered System utilizing Class A Lithium Iron Phosphate (LiFePO₄) technology for Maximum Safety, Performance, > 4,000 charge cycles (> 10 years).



Ability to control your cleaning performance by selecting from the assortment of nozzles to meet your cleaning application.



Ability to select the motor RPM by adjusting the Potentiometer which adjusts the water volume and pressure for a tailored clean.

“Working Together For A Cleaner, Greener Tomorrow”



TUFFY
CLEANING SYSTEMS

1-877-TuffyCS or 1-877-883-3927
sales@tuffycs.com
www.TuffyCleaningSystems.com

Tuffy Cleaning Systems is at the forefront of innovation in battery powered pressure washer technology. The Tuffy PowerLoad is designed for multiple flow and pressure settings to optimize your cleaning, simply change the nozzle or adjust the dial setting to conserve water and extend your run time while saving energy and water. With performance between 2.2 and 4.2 GPM and 600 to 4000 PSI and multiple power modules to choose from, **that means the performance you want, when you want it!**

The rugged aluminum frame not only looks good going down the road, but it is corrosion resistant, built to last and environmentally friendly as aluminum is recyclable and doesn't need to be painted. The adjustable high efficiency heat exchanger utilizes similar technology to that used on the hybrid electric buses, simply hit the switch when you need some heat on your tougher cleaning tasks. The Tuffy PowerLoad will change the way you clean!

“Working Together For A Cleaner, Greener Tomorrow”

- Zero Emissions Pressure Washer—Improving Air Quality
- Quiet Operation—Reducing Noise Pollution
- Factory Installed “Optional” High Efficiency Heat Exchanger
- Integrated Charging System—Comes with Standard Plugs
- Water Conserving Modes—Reducing Water Waste
- Belt Driven Triplex High Pressure Pump for Longer Life
- Auto Slow/Idle Down Technology — Saves Energy
- Designed to fit in Pickup Box (84L x 48W) Appropriate For Weight
- 12 Month Limited Warranty, 5 Year Limited Battery Warranty
7 Year Limited Pump Warranty



**DESIGNED &
ASSEMBLED IN
USA**

System Features

- Heavy Duty Aluminum Skid Base w/ Forklift Pockets
- 200 Gallon Supply Tank With Automatic Level Control and Low Water Shut Off
- System Drain and Blow Down Ability
- Draw from Supply Tank or Garden Hose
- Easy Select Flow and Pressure Settings to Optimize your Cleaning Needs

System Includes

- 100 ft Low Pressure Feed Hose and Hose Reel
- 100 ft High Pressure Hose and Hose Reel
- Relaxed Grip Trigger Gun and 48” Molded Lance
- QC Nozzle Set 3.7 to 6.0 in 15°, 25° and 40° (30 nozzles)
- Turbo and Blaster Nozzles for Harder Cleaning
- Chemical Injector Standard

Model Specs

*MFG Model	Power Module		GPM		PSI		**Run Time (hrs)		Full Charge (hrs)		Weight (lbs)	
	kW	Ah	Min	Max	Min	Max	Min	Max	125v	250v	Dry	Wet
CS84B36-200-440-L	36	375	2.2	4.2	600	4000	2:45	18:40	n/a	5.5	1487	3155
CS84B48-200-440-L	48	500	2.2	4.2	600	4000	3:35	27:00	n/a	7.25	1572	3240

*MFG Model Listed Above Includes Factory Installed "Optional Heater" OFHE-12VDC-450 and TSAL000 Hose Reel Rack

** Run Times @ 100% Duty Cycle with 20% Reserve Programed and Hot Water >4,000 Charge Cycles

Unit Net Dimensions = 84.1L +18.13 Overhang (102.23L) x 48W x 45.25H

Distributed by:

American Pressure Inc
3810 West Broadway
Robbinsdale, MN 55422

sales@americanpressureinc.com
763-521-4442
www.AmericanPressure.com

